

Jsmea News

The International Maritime Exhibition SMM Istanbul 2011



Site of SMM Istanbul 2011

JSMEA participated for the first time in the international maritime exhibition SMM Istanbul 2011, together with 11 member companies and one non-commercial organization, under a grant from The Nippon Foundation. The exhibition was held from January 26 to 28 at the Lutfi Kirdar Convention & Exhibition Centre (ICEC) in Istanbul, Turkey.



The exhibition's opening ceremony

Report on SMM Istanbul 2011



A scene from the exhibition



Consul General Katsuyoshi Hayashi of the Japanese Consulate General in Istanbul visits the Japanese Booth

About 150 companies from 30 countries exhibited in at this event. Japan, Germany and Denmark set up their own country's booth. Although the exhibition hall was rather quiet, having only 2,000 visitors (according to a rough estimate by the organizer), the Japanese booth attracted more visitors, including Japanese Consul General Katsuyoshi Hayashi in Istanbul, than other booths, indicating greater interest in Japanese products.

JSMEA took the opportunity of SMM Istanbul to organize a three-hour seminar to introduce products (with the support of Nippon Kaiji Kyokai (Class NK)), in which the six member companies listed below gave presentations to Turkish shipowners, shipbuilders and design consultant firms, among others.

About 60 and 80 persons attended the seminar and a reception, respectively, that followed.

The seminar called forth active responses. Some recorded the event with a camera, while others, after the seminar ended, contacted presenters directly.



Address to open the seminar

On the final day of the exhibition, there was an opportunity for participants to tour a shipyard through



Seminar attendants listening to a presentation

an arrangement by the organizer, allowing them gain firsthand knowledge of the shipbuilding situation in Turkey.

The association will learn lessons from the experience gained from this exhibition, and improve its display strategies accordingly to make its participation more fruitful in acquiring business opportunities.

The participants from JSMEA also visited the Turkish Chamber of Shipping and the Turkish Shipbuilders' Association to learn about plans of the Turkish shipbuilding industry, among other things, and discussed how Japan could tto better contribute to their further development. These opportunities made their visit to Istanbul even more successful.

[Numbers of exhibitors and visitors]

Number of exhibitors:

About 150 (from 30 countries)

Number of visitors: About 2,000

(Both according to a rough estimate by the organizer)

Floor space of JSMEA's booth: 102 m²

No. of exhibitors from JSMEA: 11 companies and one noncommercial organization

(Occupying exhibition floor spaces)

Akasaka Diesels LimitedLtd.,; Fuji Trading Co., Ltd., Manabe Zoki Co., Ltd., and Nippon Kaiji Kyokai (Class NK)

(Exhibiting panels)

Azuma Kako Co., Ltd., Nabtesco Corporation, NIPPON HAKUYO Eelectronics, Ltd., and Yaand Yanmar Co., Ltd.

(Distributing product catalogs)

Uzushio Electric Co., Ltd., Mitsubishi Kakoki Kaisha, Ltd., Nishishiba Electric Co., Ltd., and Yamashina Seiki Co., Ltd.

(Participants in the seminar)

Akasaka Diesels Ltd., Manabe Zoki Co., Ltd.,

Azuma Kako Co., Ltd., NIPPON HAKUYO

electronicsElectronics, Ltd., Mitsubishi Kakoki

Kaisha, Ltd., and Nakashima Propeller C o., Ltd.

(The participants are listed in a random order.)

JSMEA Participate in Nor-Shipping 2011

NOR SHIPPING
OSLO
MAY 24-27
2011



JSMEA will participate in Nor-Shipping 2011 to be held on May 24-27, 2011 in Lillestrom, Norway, under a grant from The Nippon Foundation.

This time again, JSMEA will set up the Japan booth with the Japan Ship Exporters' Association (JSEA), where 11 member companies will display their exhibits in a 210-m² space. The upcoming exhibition will be the 23rd edition of this biannual event, an established major international maritime tradeshow along with Posidonia, which is also held every other year. Nor-Shipping 2011 is expected to attract not only Norwegian shipowners and offshore businesspersons but also many from the maritime community in the rest of the world. It will also feature seminars on maritime topics.

By participating in this exhibition, JSMEA will introduce technologies and services of Japanese marine equipment manufacturers and, in cooperation with the JSEA, make better known the excellence of the whole Japanese shipbuilding and marine engineering industries.

[JSMEA EXHIBITORS LIST]

Azuma Kako Co. Ltd.
Daihatsu Diesel Mfg. Co. Ltd.
Fuji Trading Co., Ltd.
"HSN KIKAI KOGYO CO., LTD.
(Heishin Pump Works Co., Ltd.)"
Kawasaki Heavy Industries, Ltd.
MOL Techno-Trade, Ltd.
Nabtesco Corporation
Niigata Power Systems Co., Ltd.
Nishishiba Electric Co., Ltd.
Taiyo Electric Co., Ltd.
Yanmar Co., Ltd.

JAPAN MARINE EQUIPMENT ASSOCIATION /
JSMEA

Daihatsu Develops Eco-Friendly Diesel Engines 6DE-18, 6DE-23

1. Introduction

Daihatsu Diesel Mfg. Co., Ltd. has developed eco-friendly diesel engine models 6DE-18 and 6DE-23 designed to reduce the load on the global environment, with great potential to successfully address environmental problems expected to worsen in the coming years. Notable features of the new products are described below.

2. Concepts Underlying the Development

The manufacturer set targets of development in five aspects: 1) eco-friendliness, 2) durability and reliability, 3) economy, 4) security and safety, and 5) handling ease; and took up the following three development concepts together covering all these targets.

(1) Earth-Friendly Environmental Harmony

- Reduced exhaust emissions
- Cutbacks on and control of harmful substances

(2) Enhanced in durability and reliability for the long life

- Savings in operating costs
- Reliable engine start-up
- Secured lubricating oil performance over long service life

(3) Improvement in safety and assurance

- Complete fire prevention
- Simplified outfitting work
- Easy-to-handle and directly fitted engine controller

3. Specifications of the Engines

Table 1 shows the main particulars of the 6DE-18 type engine, and Table 2, those of the 6DE-23 type engine.

Engine type		6DE-18		6DEM-18	
Application		Marine auxiliary engine		Marine main engine	
Cylinder bore	mm	185		185	
Piston stroke	mm	280		280	
No. of cylinders		6		6	
Engine speed	min ⁻¹	720	900	750	900
Engine output	kWm	-		540-680	680-850
Generator output	kWe	360-635	400-808	-	

Table 1. Main particulars of 6DE-18 type engine

Engine type		6DE-23		6DEM-23	
Application		Marine auxiliary engine		Marine main engine	
Cylinder bore	mm	230		230	
Piston stroke	mm	320		320	
No. of cylinders		6		6	
Engine speed	min ⁻¹	720	900	750	900
Engine output	kWm	-		950-1,200	1,200-1,500
Generator output	kWe	760-1,140	988-1,425	-	

Table 2. Main particulars of 6DE-23 type engine

Also, photographs of the 6DE-18 type engine and the 6DE-23 type engine are shown in Fig. 1 and Fig. 2, respectively.

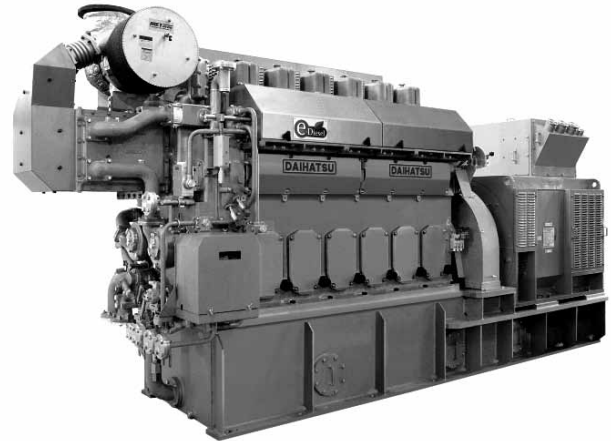

Fig. 1. External view of 6DE-18 type engine

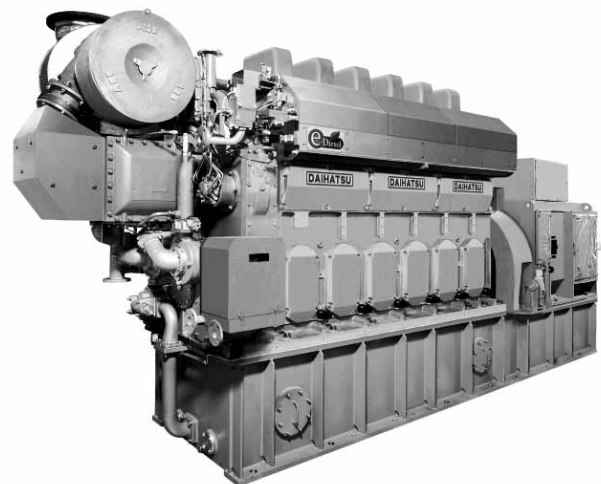

Fig. 2. External View of 6DE-23 type engine

4. Notable Features of the Engines

The DE engines embody Daihatsu technology based on its long experience in the development, manufacturing, marketing and servicing of engines, as well as the manufacturer's proven sales records, to provide products that not only satisfy environmental requirements but also have advanced performance features, together with high reliability and durability.

The 6DE-18 and 6DE-23 types of engines are compatible with both generator engine and main engine specifications.

Regarding generator engine specifications, the 6DE-18 type engine is enabled to cover the power output range for Handysize to Capesize bulk carriers and Aframax tankers. The 6DE-23 type engine's output range is suitable for PCCs, feeder containerships and VLCCs. As regards main engine specifications, both types can cover the output range of 540 kWm to 1,500 kWm making them suitable for work vessels and ferries, among others.

(1) Eco-Features Friendly to the Earth

The International Maritime Organization's Tier II Standard for nitrogen oxide (NOx) emissions already taken into force (in 2011), as well as its Tier III Standard, which is even more stringent and scheduled to become effective in 2016, must be satisfied.

As regards sulfur oxide (SOx) emissions, low-sulfur fuel oil with a sulfur content of 0.1% should be used, while CO₂ reduction requires a cutback on fuel consumption.

These difficult problems are addressed for DE engines by the following means.

1. Reduction of exhaust gas emission

In specific terms, the IMO's Tier II Standard on NOx has been met by engine tuning that combines adjustment of the fuel injection timing, an appropriate designing of the combustion chamber shape plus the adoption of a fuel nozzle injection port matching the shape, the regulation of the intake/exhaust valve timing and the use of high efficiency turbochargers with a high pressure ratio.

As shown in Fig. 3, NOx emission and fuel consumption are in a relationship of trade-off with each other, in which a reduction in one would result in an increase in the other. Therefore, to reduce both factors at the same time, fuel consumption reduction measures including a boost in explosion pressure and a cutback on mechanical losses were combined to complement NOx reducing measures.

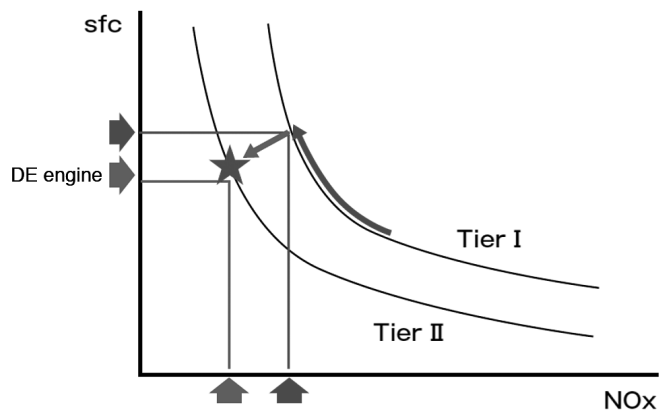

Fig. 3. Relationship between NOx and fuel consumption

2. Reduction and management of harmful substances

The Ship Recycling Convention, which will take effect in a few years, was adopted with a view to preventing environmental pollution and hazards to workers caused by harmful substances released in the process of ship demolition.

Not awaiting the effectuation of the convention, DE engines will reduce, ahead of the compulsory regulation, their contents of designated harmful substances and their management by recording the types, locations and quantities of the pertinent substances.

(2) Enhanced durability and reliability over long service life

1. Savings in fuel consumption

Enhanced durability and reliability over a long service life contributes to savings in operating costs. Thus, the cost savings are made possible by enhancing the durability and reliability of engine parts, reducing fuel consumption, keeping a

low level of lubricating oil consumption for a long period and shortening the time required for maintenance work.

Therefore, the following specific measures are taken to enhance the durability and reliability of engine parts:

- Increasing the rigidity of cylinder heads, strengthening the cooling of cylinder heads and of areas around the fuel nozzles;
- Special surface treatment of fuel injection pump plungers;
- Use of horizontally trisected connecting rods;
- Chromium plating of piston ring grooves;
- Four-ring configuration comprising three compression rings and one oil ring;
- Use of protective rings; and
- Special stem sealing for stabilization of lubricating oil quantities supplied to intake and exhaust valves.

All these features embody Daihatsu's long built-up experience.

To further quicken and facilitate maintenance and to enhance the accuracy of tightening, cylinder head bolts, main bearing bolts and crankpin bolts, which are main parts in this respect, are hydraulically fastened.

2. Reliable engine start-up

In order to enable the engine to start without fail, a direct pneumatic driving system (start-up valve system) unaffected by the quality of air is used for start-up as shown in Fig. 4.

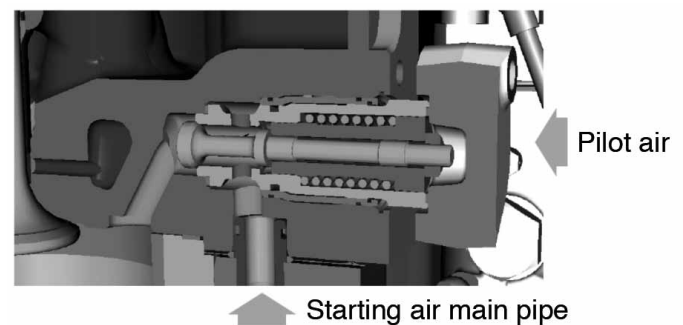

Fig. 4. Start-up valve

3. Secured lubricating oil performance over long service life

In order to maintain the properties of lubricating oil for a long period, it is essential to reduce combustion residuals that would invite deterioration of the oil.

To achieve this purpose, combustion is improved and filtering is strengthened. A large bypass filter (Fig. 5) for removing sludge in lubricating oil and an automatic backwash filter (Fig. 6), which requires no routine maintenance and prevents foreign matter from invading into the engine, are standard equipment items.

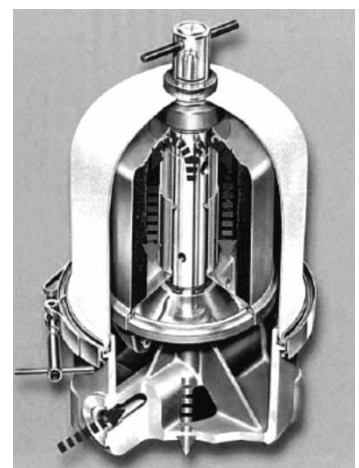

Fig. 5. Large bypass filter



Fig. 6. Automatic backwash filter

(3) Enhanced security and safety

1. Complete fire prevention

From the viewpoint of enhanced security and safety, high temperature parts are completely protected against fires, which would lead to a serious accident, and thorough measures are taken to prevent fuel oil and lubricating oil from scattering.

(See Fig. 7 and Fig. 8.)

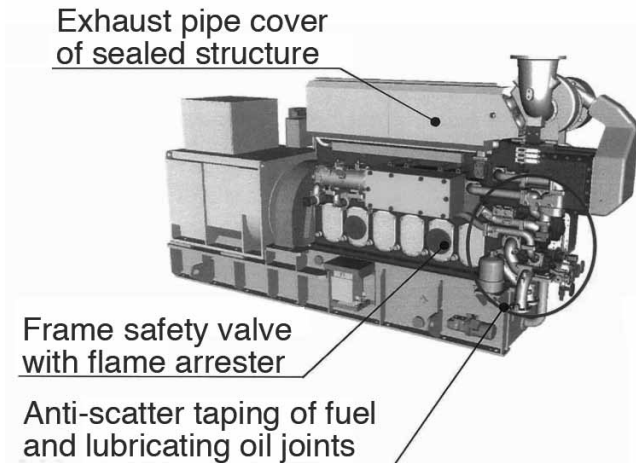

Fig. 7. Fire-preventive measures (exhaust side)

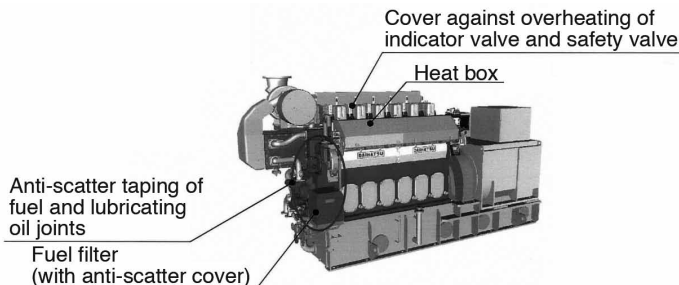

Fig. 8. Fire-preventive measures (fuel injection pump side)

2. Simplified outfitting work

To save on labor of outfitting work for engine installation, positions of connection between engine piping and hull piping are concentrated in one area ahead of the engine. Maintenance is facilitated by reducing the number of pipes and unitizing accessory items. (See Fig. 9).

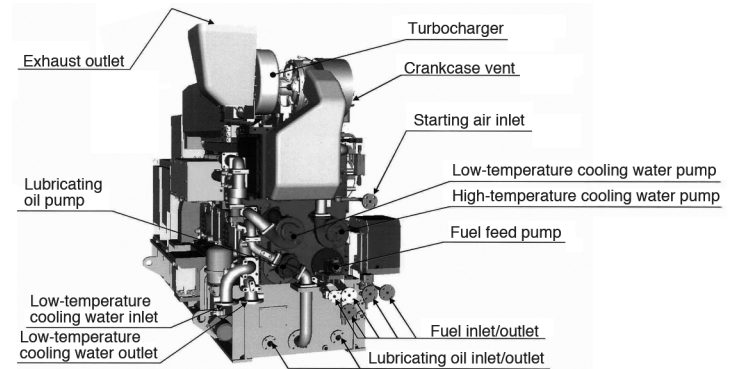

Fig. 9. Positions of connection to hull piping

3. Easy-to-handle directly fitted engine controller

The engine control system, which previously was separately installed, is made more compact and integrated with the engine.

This new system has various value-adding functions including information inputting to radio terminals, in addition to equipment for onboard/onshore communication and the onboard LAN. (See Fig. 10.)

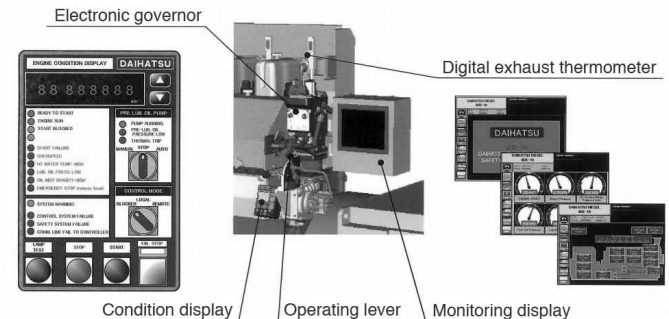

Fig. 10. Directly fitted engine controller

5. Closing Remarks

The DE engines have been developed to achieve the three key concepts of environmental friendliness, long service life and enhanced security and safety — based on the manufacturer's sales success of more than 6,000 units of its main product DK engine — and made available on a commercial basis.

The new engines are of cause considered for the IMO's Tier III Standard on NOx, scheduled for effectuation in 2016.

Daihatsu Diesel is determined to adapt its products to the diverse needs of its customers and develop engines even more friendly to the environment.



DAIHATSU DIESEL MFG. CO., LTD.

Address: 16-11, Nihonbashi 1-chome, Chuo-ku, Tokyo 103-0027, Japan
 Tel: +81-3-3279-0827 Fax: +81-3-3245-0395
 URL: <http://www.dhtd.co.jp>

Ship Stability Monitoring System

The Ship Stability Monitoring System is a product developed under a two-year (2008/2009) project with a grant from The Nippon Foundation.

The metacentric height (GM), which is one indicator of the ship's stability, is an extremely important factor in stable sailing, and knowing the correct GM in any given state of navigation is of vital importance. Conventionally, GM can be accurately known only under the specific conditions of the inclining experiment at the time the ship has been newly built. Thus, GM presented by the shipyard is the result of calculation based on the supposed weights of cargo, fuel, store and other loads and of the position of center of gravity, which are different from their corresponding values in the actual sailing state. As seen above, the surest GM measurement comes from the inclining experiment, but it is unrealistic to confirm GM on every voyage.

Typically a loading computer, now extensively found onboard, is used to estimate the weight of payload and the position of center of gravity, both varying with the type of cargo; calculate the position of center of gravity of the ship (KG); further consider the free-water effect; and figure out GM from KM at the draft then.

The recently developed "Ship Stability Monitoring System" employs the method of measuring the ship's free-rolling period and calculating GM from the natural frequency obtained from the measured period.

To fulfill these techniques, firstly, the development of a high-performance oscillation period measuring sensor which accurately determinates the rolling period was completed. Secondly, the rolling period thereby obtained was converted into one model, which is the autoregressive model statistically well-known.

As a result of calculation by applying this autoregressive model to the actual rolling data measured on board, the method was completed by providing the system with a technique of estimating

the rolling period from the relationship between the characteristic root and the rolling period.

This development project is very unprecedented, which has made it possible to display the ship's stability performance in a time series by actually measuring the free-rolling period instead of relying on the fixed GM value calculated ad hoc as stated above, analyzing by a statistical technique the rolling period which varies from moment to moment and determining on that basis the stability range indicated by the natural frequency.

The data of rolling period actually measured on board many different-type ships for two years with a high-performance oscillation period measuring sensor has been verified by comparison with measurements obtained with an optical fiber gyro. Analysis of the spectra obtained from ship's rolling showed good agreement in terms of both the accuracy and comparison data of the frequency characteristics, and proved bright prospects for practical use of this developed system.

The Ship Stability Monitoring System is configured with a high-performance oscillation period measuring sensor and a monitoring equipment. Its development has been completed with successful achievement of the objective of making it available for practical use, as endorsed by the analytical results obtained from tests on board many ships and, at the same time, of keeping the cost at a reasonable level for extensive use in the maritime industry.

After the completion of the development project, the manufacturer, Utsuki Keiki is repeating on-board tests for application to a variety of ship types to achieve an optimal system design required by shipyards and shipowners, and expects to start supplying the new product to the maritime industry around the fall of 2011.



Seminar attendants listening to a presentation

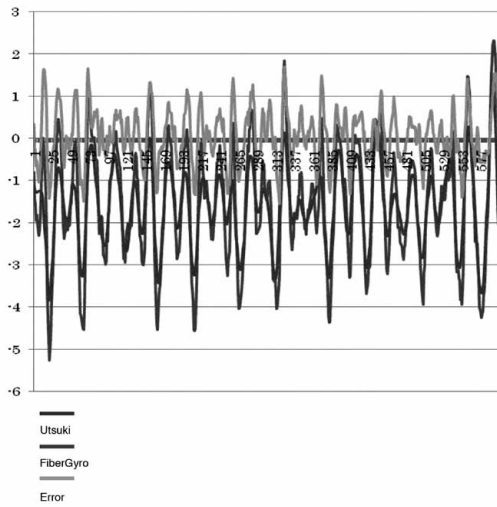

UNIT SETTING DISPLAY

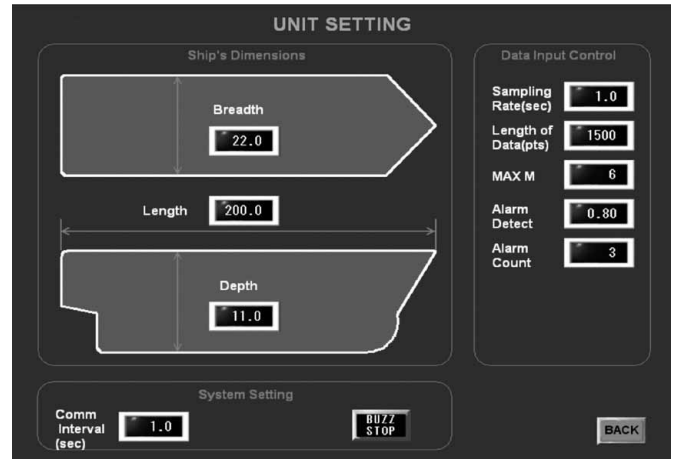

ROLL DATA DISPLAY

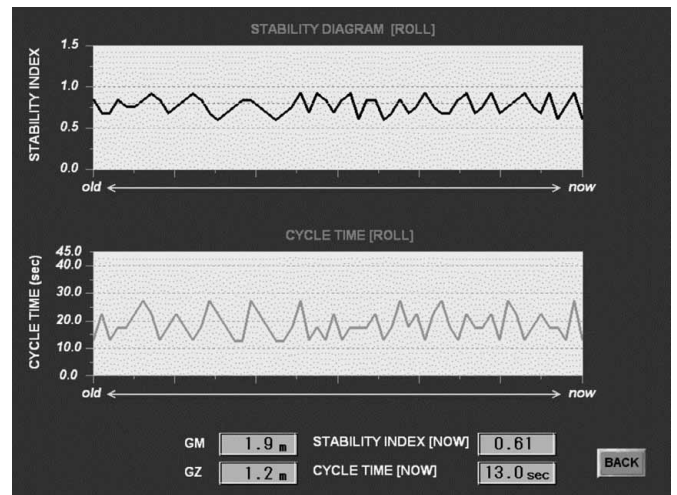

PITCH DATA DISPLAY

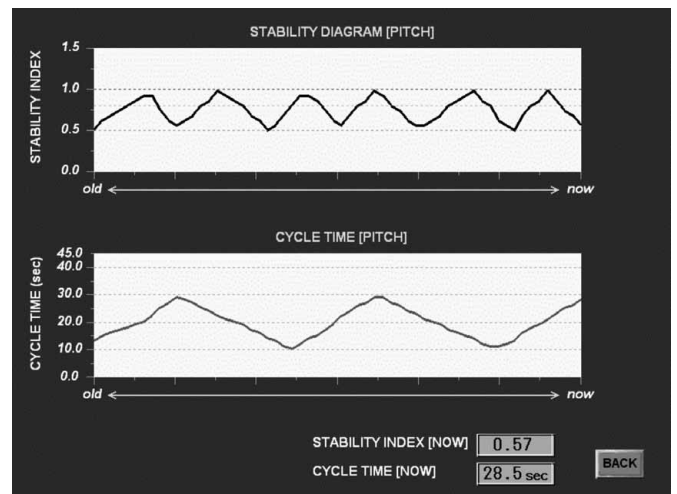

UTSUKI KEIKI CO., LTD.

UTSUKI KEIKI CO., LTD.

Address: 3530 Kamiyabe-cho, Totsuka-ku, Yokohama, JAPAN
 Tel: 81-45-813-8481, FAX : 81-45-813-8491
 URL: <http://www.utsukikeiki.co.jp/>

Shot Beam 25 Flameproof Enclosed Type Handy Light

Outline

Shot Beam 25 is a flameproof enclosed-type handy light with a built-in battery, and a HID lamp light source radiating powerful light. It is suitable for use in maintenance and inspection work in hazardous places. These include plant facilities or other business establishments handling inflammable gas or other hazardous matters, which, if emitted or leaked into the atmosphere, will mix with air to form an explosive ambience that is too great to ignore, as electrical equipment could ignite it and cause an explosion.

This product has passed the test of the Technology Institution of Industrial Safety (TIIS) for explosion-protected electrical appliances and the type certification test of the Nippon Kaiji Kyokai (Class NK).

Features

- (1) It is a handy light developed for marine use that meets the requirements of flameproof enclosure specifications.
- (2) As it is a certified flameproof enclosed product, the light can be safely used aboard ships carrying hazardous cargo or designated explosion-protected areas.

Specifications

Model denomination	SXP-M25
Type of flameproof structure	Ex dIIB+H ₂ T3
Protection class	IP66
Ambient temperature for use	-10 to +45° C (though freezing is unacceptable)
Suitable lamp	HID 25 W
Service life of lamp	About 2,000 hours
Lighting duration	About 2 hours (from fully charged state)
Power source	Lithium ion battery built into lighting unit DC 14.8 V, 4 Ah, 65 Wh
Charging time taken	About 4 hours
Luminous Intensity	250,000 cd or More
Light beam angle (1/10)	About 5°
Size (D × W × H)	240 × 136 × 180 (mm)
Mass	About 4.3 kg (including battery)

- (3) The explosive gases it can safely be used in contact with include hydrogen gas.
- (4) The color temperature of the lamp is 5,800 K, close to that of sunlight, and therefore provides excellent visibility.
- (5) It is the brightest among lights of this class, and is most suitable not only in explosion-protected areas but also for use in distant observation and on night watch.
- (6) Built of shock-resistant and sturdy aluminum in a waterproof sealed structure, the light can be used with a feel of security in any situation.
- (7) It is significantly smaller and lighter than other certified explosion-protected products of this kind.
- (8) The built-in lithium ion battery permits continuous lighting for about two hours.
- (9) A dedicated charger can charge the built-in battery from a slit behind the lighting unit.
- (10) The lamp and stabilizer are reliable Japanese products

Irradiation distance

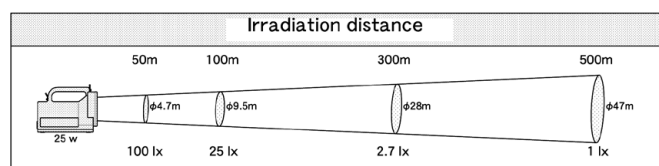

Shot Beam 25 proper



SHONAN CO., LTD.

Address: 6-5-3 Omori-nishi Ota-ku Tokyo, 143-0015 Japan
 Tel: +81-3-3762-2431, FAX : +81-9-3762-2435
 URL: <http://www.the-shonan.co.jp>

Environmentally Friendly, Fuel-saving Low-VOC Antifouling Paint SEAFLO NEO from Chugoku Marine Paints, Ltd.

Today, the need is increasing for antifouling paints having a fuel saving effect derived from reduced frictional resistance. To meet this demand, Chugoku Paints has introduced the environmentally friendly fuel-saving low-VOC antifouling paint SEAFLO NEO, integrating the latest achievements in technology.

VOC (volatile organic compounds) are solvents, such as toluene and xylene, which volatilize when the paint is being applied and invite generation of photochemical smog or some other pollutant. In view of this problem, the company attempted to reduce VOC emissions into the atmosphere by lowering the VOC content in paints, and succeeded in bringing down the VOC content by approximately 30% from around 500 g/L in conventional paints to 330 g/L in the new product.

SEAFLO NEO, embodying for the first time anywhere a new technology that uses a new polymer unprecedented in its low viscosity. Jointly developed by The National Maritime Research Institute (NMRI) and The Cooperative Association of Japan Shipbuilders (CAJS), the polymer enhances the leveling performance of the coat surface, whose ultra-smoothness is thereby secured and contributes to fuel saving.

Friction is reduced by using a specific low viscosity resin in addition to the application of a surface-adjusting technique that gives a coat surface having a long

wavelength that is smaller in peaks and troughs in the three-dimensional analysis graph representing the coat surface coarseness. This results in a smooth coat surface excelling in leveling performance in the process of film formation. In the environmental load aspect, a significant cut in the quantity of solvent is achieved by the use of two-part paint, resulting in restrained scattering of paint dust compared with paints of solvent volatilizing type.

The reduction in friction is confirmed by testing with a high precision double cylinder type frictional resistance measuring apparatus in comparison with conventional antifouling paints. This measuring apparatus, jointly developed by NMRI and the Tokyo University of Science, is owned by Chugoku Paints. The test revealed that SEAFLO NEO was reduced in frictional resistance by 8% over that of conventional antifouling paints. This promises a 3% to 5% fuel saving when the new type paint is applied to real ships. The testing apparatus, which uses a large drum, has a measuring error of 0.5% or less in a certain environment and under certain conditions, and the faithfully reproducible data it gives can be regarded as scientific endorsement of the fuel saving effect of SEAFLO NEO

Surface coarseness of conventional paint

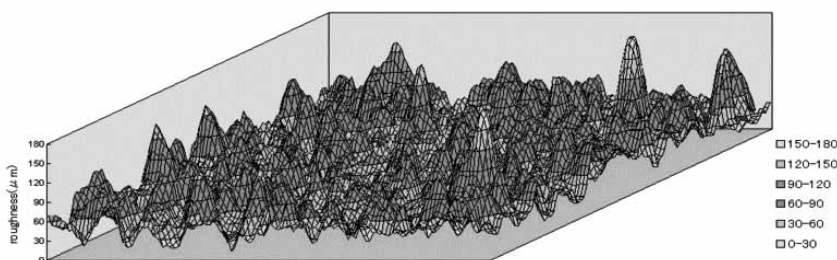

Surface coarseness of SEAFLO NEO

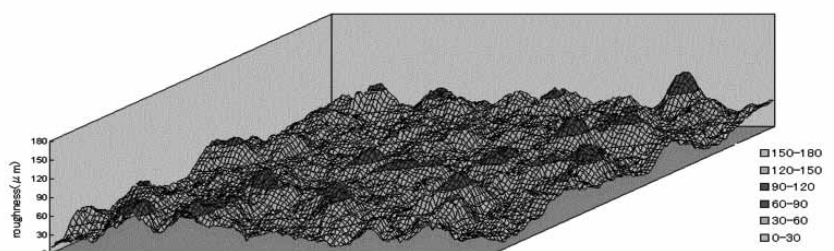



Large drum (31 cm in diameter and 30 cm in height) of the double cylinder type water current frictional resistance measuring apparatus:

By turning of the outer circumference of the cylinders at 1,000 rpm, the torque working on the inner cylinder can be measured up to 32 knots in the circumferential speed equivalent at the theoretical maximum, and the frictional resistance can be verified with faithful reproducibility.

The antifouling performance provided by the characteristics of the new specific resin used is at least equal to that of comparable conventional paints.



**A scene of SEAFLO NEO application:
A smooth surface can be obtained by the ordinary painting method.**

In addition, the VOC reduction also enables the new

product to be required in smaller quantity per m², with corresponding reduction in the absolute quantity of use, the number of man-hours spent in application and the intensity of odor, among other respects.



CHUGOKU MARINE PAINTS, LTD.

Address: Tokyo Club Building, 2-6, Kasumigaseki 3-chome, Chiyoda-ku, Tokyo, 100-0013, Japan
Tel: +81-3-3506-3951, FAX : +81-3-5511-8541
URL: <http://www.cmp.co.jp/>

Gist of JSMEA's Action Plan 2011 In Pursuit of Greater International Competitiveness and Further Animated Industrial Activities

**February 17, 2011
Japan Marine Equipment Association (JSMEA)**

1. Promotion of communication and collaboration within industry and outside

(1) Strengthening of communication and collaboration within industry

- Response to reform of public-interest entity system
- Further vitalization of sector-by-sector working groups, etc.
- Regarding the Conference of Next-Generation Marine Equipment Business Managers, etc. (Next-Generation Conference?)
- Anti-imitation measures
- Responses to regulatory issues in and out of Japan
- Promotion of membership expansion
- Collaboration with regional marine equipment associations

(2) Promotion of communication and collaboration with client industries

- Shipping industry
- Shipbuilding industry
- Government agencies
- Others

(3) Specific actions in collaboration with client industries

- Research on establishment of verification technology for engines equipped with SCR system (FY 2010-2012)

2. Promotion of retention and development of human resources

- Positive actions to retain and develop human resources
- Recognition of Marine Equipment Meisters
- Retention of human resources

- Education of working adults

3. Positive contribution to safety and environmental conservation

(1) Strengthened responses to regulation by IMO, etc.

(2) Actively addressing environmental issues

- R&D of "Super-clean Marine Diesel" (FY2009-2011)
- Matters related to energy-saving
- Ship recycling

4. Vitalization of technological development

(1) Financial aid to new product development

- Projects of financial aid to new product development

(2) Background improvement for vitalization of new product development

- FS projects
- Study conferences
- Marine Technology Forum
- Discussion on vitalization of technological development

5. Encouragement of global presence

(1) Background improvement for global presence

- Promotion of international exchanges
- Discussion of medium- to long-term global perspective

(2) Reinforcement of international public relations and publicity

- International exhibitions and seminars, and visits to shipowners and shipbuilders
- International newsletter JSMEA NEWS



JSMEA

Japan Marine Equipment Association

Head Office: 6th Floor, Kaiyo Senpaku Building, 15-16, Toranomom 1-chome, Minato-ku, Tokyo 105-0001, Japan
Tel.: +81-3-3502-2041 Fax: +81-3-3591-2206 E-mail: info@jsmea.or.jp URL: http://www.jsmea.or.jp

Overseas Offices:

Japan Ship Centre (JETRO), Ship Machinery Department

2nd Floor, 6 Lloyd's Avenue, London EC3N 3AX, UK
Tel.: +44-207-680-9456 Fax: +44-207-680-9416

JETRO Shanghai, Ship Machinery Department

21st Floor, Shanghai International Trade Centre, 2201, Yan An Xi Road, Shanghai 200336, P.R.C.
Tel.: +86-21-6270-0489 Fax: +86-21-6270-0499

JETRO Singapore, Ship Machinery Division

Hong Leong Building, #38-01 to 05 #37-02A 16 Raffles Quay, SINGAPORE 048581
Tel.: +65-6429-9522 Fax: +65-6224-1169



Jsmea News is published under a grant from The Nippon Foundation.

Printed in Japan 2011. 3