

SHIPBUILDING IN

Japan

Energy saving technologies

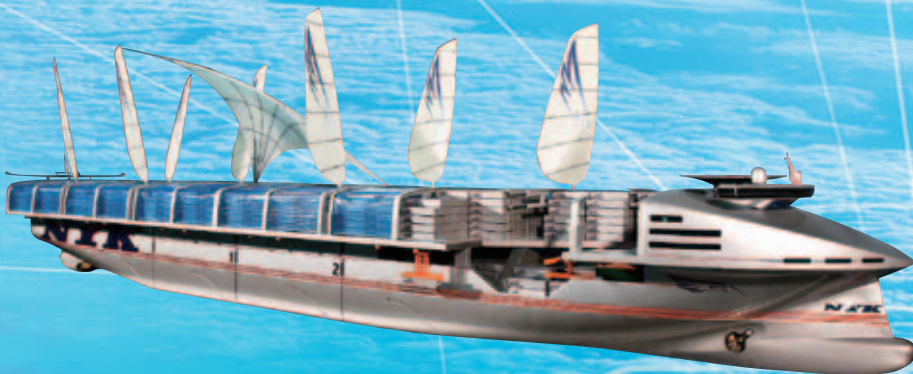
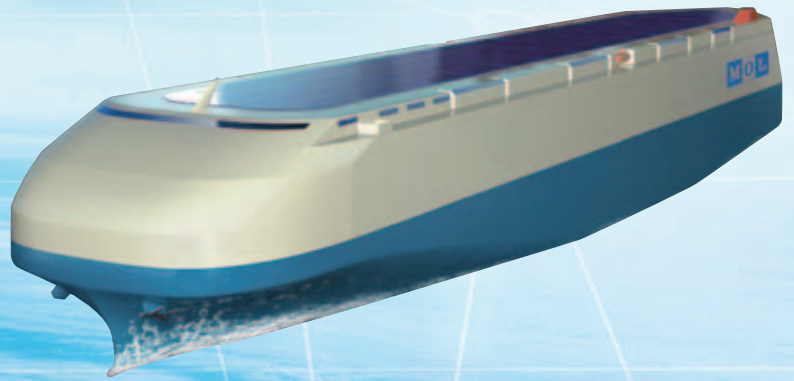
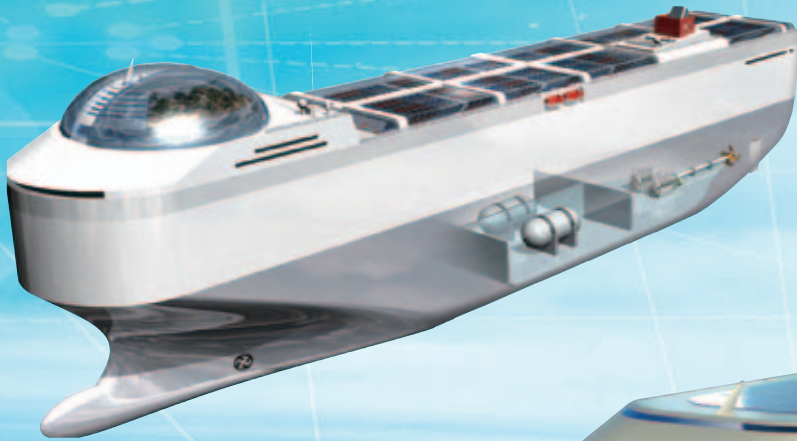

Outline of Japanese Shipbuilding Industry

Characteristics of Japanese Shipbuilding Industry



質 Quality

High Quality, High Performance

Backed by Japan's outstanding technology and rich experiences accumulated over the years, Japanese shipbuilding and marine equipment industries provide a wide range of ships equipped with both "High Performance", which allows safe and economical operation of ships, and "High Quality", which promises high reliability and durability.

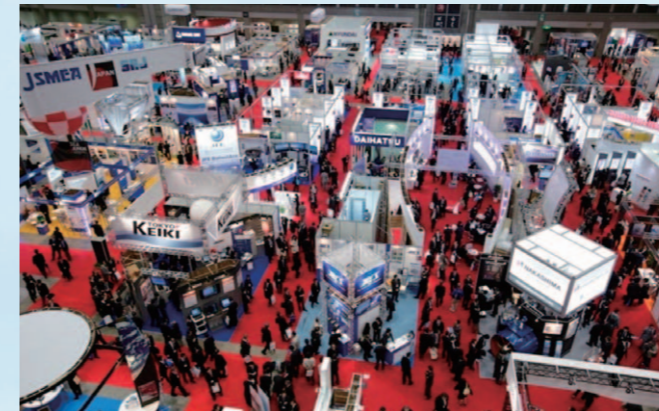
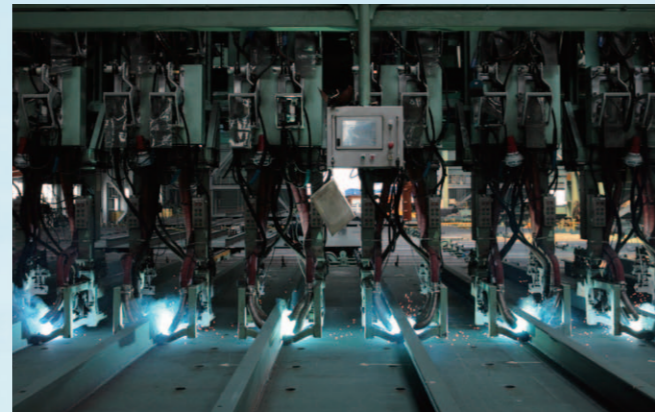

集 Clusters

Maritime Clusters

Japanese shipbuilding industry, marine equipment industry and marine shipping industry, each attaining global top level, closely work together, forming "maritime clusters". This cooperative relationship creates a synergy that is unique to Japan, permitting effective quality improvement and technical development.

造船 Shipbuilding 船



伝 Skill

Hand-down of techniques and development of human resources

Although manufacturing processes are fully automated for many industrial products, there still are processes that require involvements of skilled technicians for shipbuilding, and the quality of work by such technicians significantly affects the quality and performance of ships. Japanese shipbuilding industry places emphasis on development of human resources and handing-down of techniques in order to maintain, or even to improve the quality of human resources.

技 Technology

Technological Innovation (Environmentally-Friendly, Energy Saving Technology)

Being an important social infrastructure element, ships have always been required to realize high safety and high economic efficiency, and in recent years, demands for new innovations are rising as the trends for environmental protection and energy saving emerge. In Japan, the government, private sectors and academic society work hands in hands to develop the cutting-edge technologies that help create advanced ships that meet the needs of the society and ship owners.

Ships built in Japan



Cargo ships
Oil tanker



Cargo ships
Container ship



Cargo ships
Bulk carrier



Cargo ships
LNG carrier



High value added ships
Cruise ship



Cargo ships
Car carrier



Work boats, research ships
Tugboat



Work boats, research ships
Deep Sea Scientific Drilling Vessel



Work boats, research ships
Fisheries research boat

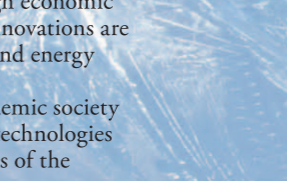

Offshore structures
Semi submersible oil drilling rig

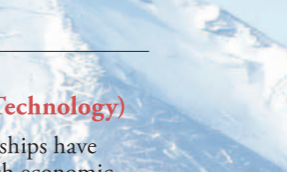

Offshore structures
Mega float



Work boats, research ships
Dredge ship



Offshore structures
FPSO



High value added ships
Patrol vessel



Work boats, research ships
PSV, AHV

Mitsubishi Air Lubrication System – MALS –

makes significant reduction of CO₂ emissions possible



MALS 14000CS

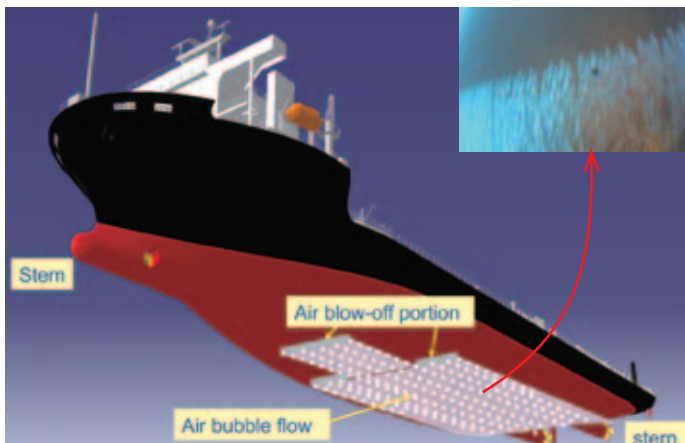

An image of an air lubrication method



Modular carrier ship "YAMATAI"

It first came to our knowledge in 1940s that there is a possibility to reduce frictional resistance between ship hull and seawater by effectively utilizing air. However, it didn't go much further than study in lab because the scale ratios of bubbles could not be adjusted in model test. Since around 2000, this possibility was started to be sought again, with experiments of air lubrication method being performed on actual ships. Mitsubishi Heavy Industries Ltd. (MHI) developed Mitsubishi Air Lubrication System (MALS), the very first air lubrication system in the world that was successfully commercialized after having its performance verified in joint verification tests with Nippon Yusen Kabushiki Kaisha and MTI Ltd., which were carried out with support from NYK-Hinode Line, Ltd., by installing MALS on module carriers "YAMATAI" and "YAMATO" and testing the system onboard (*1).

This new technology, as well as a newly developed high-efficiency ship hull form with low resistance, are adopted for MHI's new panamax class container ship, MALS 14000CS, along with other efforts to curtail CO₂ emissions. Such efforts include changes in arrangements such as placing bridge forward and exhaust funnels at the stern, additional container space under the accommodation quarter, adoption of two-engine, two-shaft propulsion system, electronically controlled diesel engine and waste heat recovery system. Thanks to these new technologies and efforts, MALS14000CS is capable of reducing CO₂ emissions by approximately 35% compared to conventional ships.

As for the performance of MALS alone, it was confirmed in sea trial before delivery, that MALS effectively reduces CO₂ emissions by approximately 10%. The verification after delivery on module carriers are currently in progress.

The followings provide brief descriptions on how this system works:

- Blowers installed onboard send air under the vessel bottom.
- The air will be blown outside the vessel from openings located at an edge of the vessel bottom.
- The air will be torn apart with the flow of seawater around the hull, covering the vessel bottom with bubbles. Then the bubbles flow toward the stern.
- Air bubble output is controlled to a level that is best suited to the speed and waterline so that the vessel bottom is surrounded by adequate amount of air at all time.
- Air bubble output is equalized by adjusting the openings of valves installed on pipes.

Mr. Shuji Mizokami, the engineering manager of Innovation & Technical Development, Ship & Ocean Engineering Division, Shipbuilding & Ocean Development of MHI, who is in charge of development of this system, says "This system is applicable to any types of ships, whether they are newly built ships or ships that are already in operation. And it makes a notable difference in efficiency when activated. This system is capable of making a considerable contribution to CO₂ emission cut from ships."

*1: This verification test project is implemented with support from Ministry of Land, Infrastructure, Transport and Tourism. It is also a joint research project with Nippon Kaiji Kyokai.

Technology to achieve world top-level generating efficiency and cut CO₂ emissions - Offshore Wind Turbine



Offshore wind turbines

Mitsubishi Heavy Industries Ltd. (MHI) is developing its business while placing focus on “natural energy” technology, which can contribute to reduction of CO₂ emissions. The company has experience of more than 30 years in development and manufacturing of wind power generation technology and its equipment, and supplies the world with wind turbines with world top level generating efficiency. MHI plans to launch 7MW wind turbines by 2015, a major innovation given that most wind turbines in the market at this moment are 3MW.

Mr. Masahide Umayu, the general manager of Offshore Wind Turbine Project Development Department, Wind Turbine Business Division, Power Systems, says: MHI’s unique hydraulic system and modular design are incorporated into our offshore wind turbine design with aim to solve a problem that is accompanied with the nature of offshore wind turbines, which are located on the ocean – low maintainability. The hydraulic system and modular design allow continuous operation of the turbine even when failures occur in some hydraulic components. This will also provide ease of component replacement in the event of failures. Instead of replacing a whole wind turbine or heavy & large components as required in the conventional design, replacement of small faulty components will be enough to resume operation with this design.

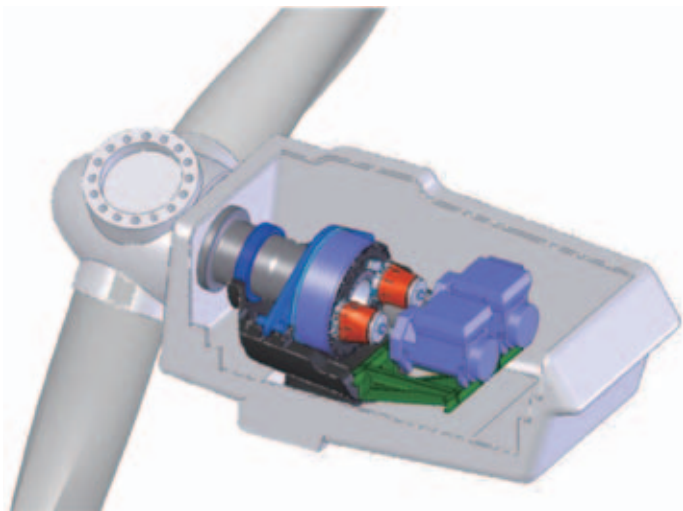

MHI's unique hydraulic system and modular design

The bigger the wind turbine unit gets, the further away from the coast the unit will be installed in order to allow smooth marine transportation. Due to this factor, it is important to give consideration to the weather and marine conditions, as well as to the ease of installation and maintenance processes. To cope with this issue, MHI is gearing up its efforts to develop vessels specifically designed for installation of offshore wind turbines, taking advantage of the experience and knowledge accumulated as a shipbuilder.

Mr. Hitoshi Kumamoto, the acting manager of Tanker & Offshore Vessel Planning, Ship & Ocean Engineering Division, Shipbuilding & Ocean Development, says about this effort, that, although the hull forms of turbine installation vessels vary depending on the usage, MHI intends to provide the customers with ships that will meet their needs, whether they are newly built ships or modifications to existing ships.



Developing ship designed for installation of offshore wind turbines (Example 1)

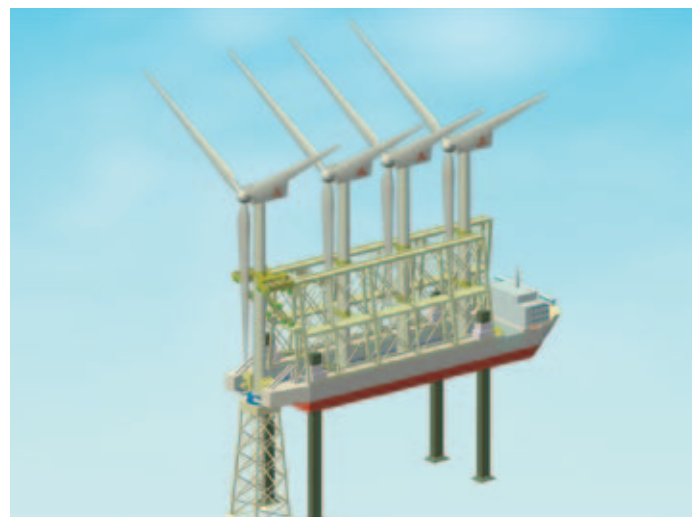

Developing ship designed for installation of offshore wind turbines (Example 2)

Ship of Next Generation “eFuture”

– realizes 30% cut in CO₂ emissions and fuel consumption

IHI Marine United Inc. (IHI MU) launched a new environmental impact reduction ship series “eFuture” in 2010. This “eFuture” series was developed by integrating environmental technologies the company has accumulated.

Currently the series consists of 13,000TEU type container carrier “eFuture 13000C”, 310,000 VLCC “eFuture 310T” and 56,000 MT

bulk carrier “eFuture 56B”. Combining IHI MU’s established technologies, this series is capable of reducing CO₂ emissions and fuel consumption during navigation by 30% compared to conventional ships.

The followings are some of the technologies that made the reductions of CO₂ emissions and fuel consumption possible:



eFuture 13000C

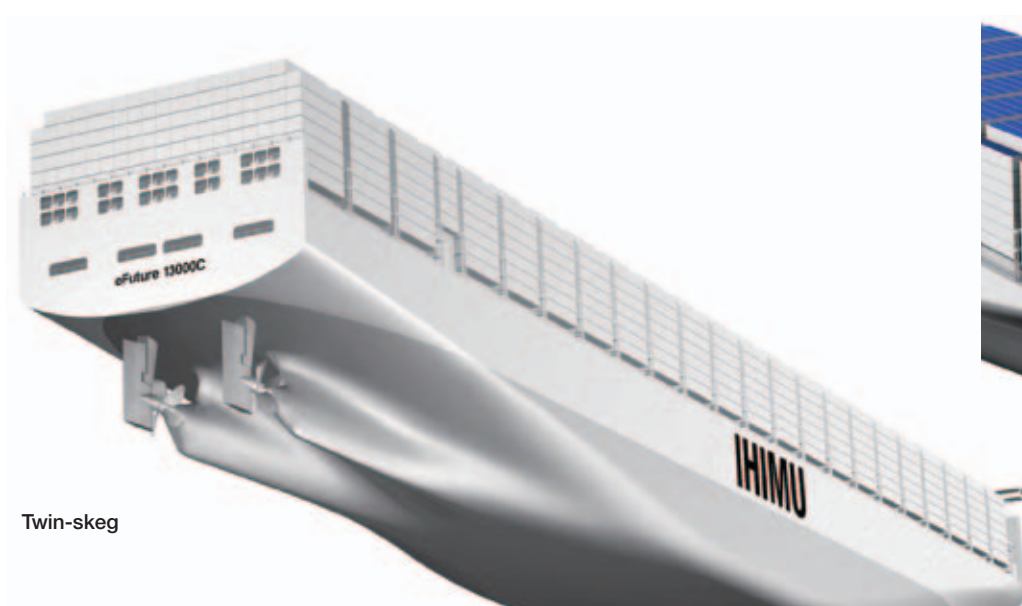

Twin-skeg



Use of natural energy &
Reduced wind resistance

[eFuture 13000C]

1. Use of natural energy: Solar panels are installed over the uppermost tier of containers, and the energy collected from the panels is stored in the lithium batteries and used for operation in the bay.
2. Reduced wind resistance: Innovative front bonnet design allows reduction of wind resistance.
3. Improved propulsion efficiency: Propulsion efficiency is signifi-

cantly improved by employing a newly-developed twin-skeg hull form.

4. Exhaust heat recovery: exhaust heat recovery is installed to utilize exhaust heat from engines, which is converted to power in steam turbines and waste gas turbines. The generated power will be used as inboard power supply.



eFuture 310T

[eFuture 310T] [eFuture 56B]

Various technologies are incorporated into the designs of eFuture 310T and eFuture 56T with aim to capitalize on the strengths of low-speed craft. Followings are some of the technologies used for these models:

1. A special bow form called whaleback bow(*1) reduces added resistance by waves and winds in rough weather.
2. Size reduction of engines: Size and weight of engines are reduced by adopting two small sized engines to drive a contra-rotating propeller.
3. Propulsive performance is significantly improved by combining IHI MU's advanced contra-rotating propeller (CRP) with other energy saving technologies.

*1: Whaleback Bow: Bow having inward flare suppresses reflection of incident waves and reduces resistance increase in waves. In addition, the devices installed on accommodation reduce wind resistance. These technology are fruit of research over twenty years in IHIMU and they reduce the power of propulsion in actual sea condition.



eFuture 56B

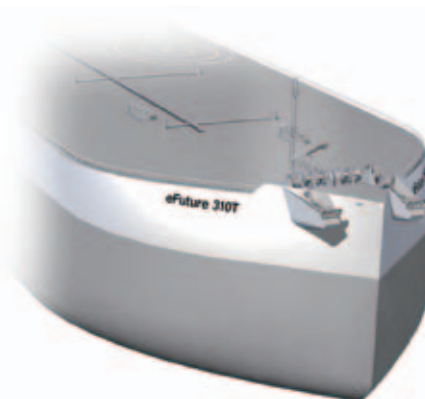

Whaleback Bow



Contra-Rotating Propella

Mr. Yoshio Otagaki, the managing director of IHI Marine United Inc. says, "The name of this new environmental impact reduction ship series, "eFuture" was derived by combining elements we care about; "Future" for the future of the earth and our lives, and "e" for "ecology", "environment", and also "economy" with customers' interests in mind. The basic concept of "eFuture" is to reduce CO₂ emissions

and fuel consumption up to 30% by combining our established, yet innovative technologies. The combinations of technologies are quite flexible, which allows us to cater to the needs of each customer. We are prepared to propose various combinations based on the requirements from the customers learned through discussions."



Conversion work on semi-submersible drilling rig

Semi-submersible drilling rig

IHI Marine United Inc. is also involved in designing, construction and modification of semi-submersible drilling rigs based on the shipbuilding technologies accumulated over the years as well as the latest technologies as mentioned above. Placing high importance on stability in rough weather, IHI MU's drilling rigs are designed to be resistant to waves. IHI MU also performs conversion works of adding floaters to aged drilling rigs to allow operations in deepwater. IHI MU possesses the technology to complete such conversion works on delivery terms as short as half a year. IHI MU plans to expand the business with focus on collaborative projects with other companies by offering designs of semi-submersible drilling rigs.

New technology to cut CO₂ emissions by utilizing exhaust gas energy

- Development of large low-speed marine diesel engine



THS

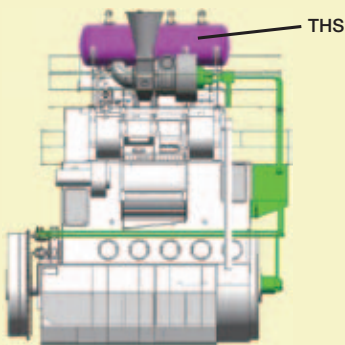

Mitsui Engineering & Shipbuilding Co., Ltd. (MES) developed a high-performance large low-speed marine diesel engine. This diesel engine is capable of converting approximately 50% of energy generated into propulsive force. To realize both environmental protection and enhanced performance of ship by improving fuel efficiency, MES is on its way to develop new technologies to utilize excessive exhaust gas energy (exhaust heat recovery) in order to make full use of the remaining 50% of fuel energy.

Various research projects are in progress, including those for the following two systems:

THS (Turbo Hydraulic System)

THS is an exhaust gas heat recovery system intended to save energy by utilizing excessive exhaust gas energy, which will be used to generate hydraulic pressure. The generated hydraulic pressure rotates motors, which then assist the rotation of crank shaft, reducing fuel consumption as a result. Test successfully showed a 4% decline in fuel consumption (CO₂ emission) at maximum continuous output (100% load), and a 3% decline at continuous service output (85% engine load).

As this hydraulic motor is smaller compared to conventional electric motors, it is also suited for installation on existing ships.

Development of this cutting-edge technology is about to be completed, and MES plans to bring this new system to market in 2012 or possibly in 2013.

EGS

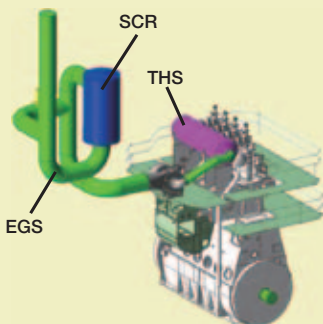

EGS (Exhaust Gas Separation System)

EGS is a system to separate excessive exhaust gas emitted from combustion room, into high temperature gas and low temperature gas. Separated high-temperature, high-energy exhaust gas is then sent to turbochargers and SCR (Selective Catalytic Reduction) which is one of the technologies developed to comply with NO_x Tier III. Through these processes, exhaust gas heat recovery rate will be improved by 1-2%, and SCR performance will also be enhanced. This system does not require burners and the size of tube reactor is reduced to half compared to conventional design, which result in space savings.

Mr. Ichiro Tanaka, Machinery & System Headquarters of MES, who is in charge of development of this technology, says "Final verification tests are currently underway for these technologies which assist in complying with international regulations on NO_x emissions, as well as reducing CO₂ emissions. We hope to launch these systems which support both environmental protection and improved fuel efficiency at the same time, at an early point."

Development of small-sized dual fuel diesel engine

- 15% CO₂ reduction effect

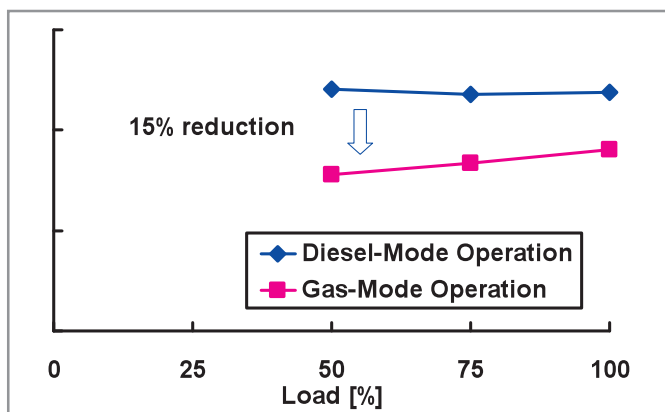

International Maritime Organization (IMO) is gradually tightening regulation on nitrogen oxides (NO_x) emission, and NO_x Tier II, effective from January 1st, 2011, requires additional cut of NO_x emission by approximately 20% compared to Tier I regulation.

Also, Tier III, which is still discussed as being applied to ship engines that are to be installed on vessels constructed on or after January 1st, 2016, requires that the vessels reduce NO_x emission in Emission Control Area (ECA) by approximately 80% compared to Tier I regulation, while concurrently satisfying NO_x Tier II in other areas.

Niigata Power Systems Co., Ltd., a company famous for Z-peller for tugboats, is currently developing marine engines that meet the requirements.

This new engine, dual fuel diesel engine, for which the design phase is completed, is being developed targeting to achieve 15% CO₂ reduction effect(*1). Based on the company's excellent development and manufacturing technology for diesel and gas engines, dual fuel diesel engine is designed to be operable using both diesel oil and LNG as the fuel, taking advantage of strengths of the two types of fuel; diesel oil for the superb cost performance, and LNG for the low emission rate of carbon dioxides (CO₂), nitrogen oxides (NO_x) and sulfur oxides (SO_x). Currently, final test before production is underway.

*1: "15% CO₂ reduction effect" is a value determined by comparatively analyzing the content of CO₂ in actual exhaust gas from diesel engine and gas engine (including gas mode operation of dual fuel engine), and is based on realistic study with the efficiency and output (P_{me}) of engines into account. It is considered to be equivalent to 20~35% reduction of CO₂ emission when estimated based on comparison of component ratios of liquid fuel and gas fuel (C/H ratio).

Dr. Masayoshi Kawakami, the executive officer and the general manager of Engineering and Technology Center, says about dual fuel diesel engine, "the research project for dual fuel diesel engine was started in 2009, making full use of our accumulated development and manufacturing technology for our trusted small to medium-sized diesel engine, as well as that for gas engine, which we started developing and manufacturing back in 1980s. The project is expected to be completed in 2012, and we are hoping to launch this engine at an early point."

Hybrid power supply system

– effective use of natural energy and excessive energy



Shipyards around the world are gearing up their efforts to develop “eco-ships” into which various measures are implemented to curb greenhouse gas emissions on voyage. Amid this trend, “Hybrid power supply system” developed by Kawasaki Heavy Industries, Ltd. (KHI) is drawing attentions of global shipbuilding industry.

This system was made possible with KHI’s self-developed large capacity nickel-metal hydride battery, “Gigacell”. When being powered by diesel generators, excessive electricity will be stored in “Gigacell”. Once sufficient electricity is stored in “Gigacell”, the generators will be stopped and the operation will be continued with the electricity discharged from “Gigacell” only. This process will be repeated over and over during the operation, resulting in a reduction of fuel consumption by the generators.

If introduced to a typical car carrier with a capacity of 6,000 passenger vehicles, CO₂ emissions on voyage can be reduced by 2%.

Battery-operated trolley and large electric bus using “Gigacell” are currently being developed by KHI, and “Gigacell” can also be used

for a smart grid. And now, this technology is applied to ships.

Distinctive features of this system are the technologies to interconnect and stably control the two devices with different usages. Of course, the two devices are “diesel generator” which generates electricity, and “storage battery” which stores electricity.

After series of trials and errors using many different types of inverters and circuit breakers, KHI’s efforts finally paid off when a stable power system was successfully established a year and a half later. After undergoing onshore verification tests, this system was installed on a solar-power-assisted car carrier “Auriga Leader” (60,123 tons), operated by Nippon Yusen Kabushiki Kaisha, for shipboard verification tests, which are currently underway, with aim to realize stable power supply with solar photovoltaic power generation and hybrid power supply system.

KHI aims to commercialize hybrid power supply system for shipboard use based on the result of the shipboard verification tests.



Ship of the year 2010 & ShipPax Award 2011



Ship of the year award, sponsored by The Japan Society of Naval Architects and Ocean Engineers (JASNAOE), is awarded to the most outstanding ship in terms of artistry and technicality that is built in Japan in each year.

For 2010, a car carrier “CITY OF ST.PETERSBURG” constructed by Kyokuyo Shipyards Corporation received the honor.

One distinctive feature of this ship is the semi-spherical shaped bow. This innovative design is what made it possible to reduce wind resistance by maximum of 50% compared to conventional designs as confirmed in wind tunnel test.

This means, when calculated at running rate of 75% in average oceanographic weather conditions of North Atlantic water, a reduction in annual fuel consumption by approximately 800 tons, which is equivalent to approximately 2,500 tons in CO₂ emission cut. It is expected to be highly effective as a countermeasure against global warming.

“CITY OF ST. PETERBURG” also received ShipPax Award 2011, which is sponsored by a Swedish publisher, ShipPax Information.

Energy saving device “STEP” reduces added resistance by wave by 18%

- Development of ship performance improvement device

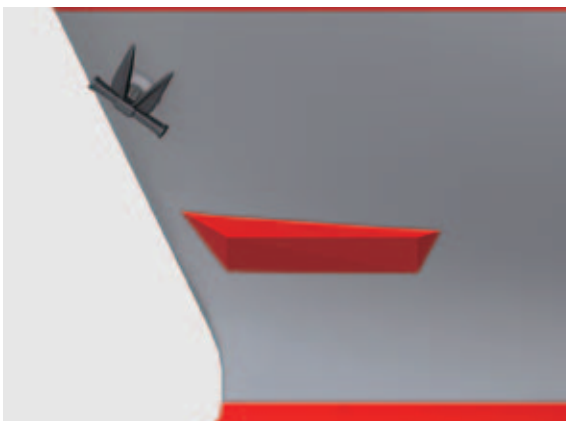

Energy saving device “STEP”

Naikai Zosen Corporation developed a new ship hull form for a pure car and truck carrier (length: 183m, gross tonnage: 46,000 tons, capacity: 5,000 cars) with energy saving device “STEP” (SPRAY TEARING PLATE) installed. This new device, “STEP” was developed, based on the findings gained from the research by National Maritime Research Institute (NMRI), with supports from Ministry of Land, Infrastructure, Transport and Tourism (MLIT), Nippon Foundation, Nippon Kaiji Kyokai (Class NK) and Shipbuilding Research Centre of Japan.

“STEP” is a plate-shaped energy saving device installed on forward draft (draught) line, designed to suppress the effects of tidal waves during rough weather. This device mitigates the slowdown of the vessel caused by waves, ultimately improving fuel efficiency.

Tank test showed a decrease in added resistance by wave by approximately 18%, and an improvement of fuel consumption by approximately 2% in Beaufort force 6 of head waves and head winds (equivalent to significant wave height of 3m and wind speed of 12.6m/s).

The test result was verified by Nippon Kaiji Kyokai by a high-accuracy combined evaluation using tank test and theoretical calculation (SPICA: Ship Performance Index Calculation Program), and was certified as being qualified to the technical appraisal service of ship performance in actual seas “10 Mode Performance Index for Ships”.

This “10 Mode Performance Index for Ships” was developed ahead of other countries, with aim to accurately and cost-efficiently assess fuel efficiency during actual operation of ship, which is impacted by waves and wind.

One benefit of this index is that actual fuel efficiency of a ship can be evaluated at the design phase.

In the midst of rising importance for countermeasures against global warming in the marine shipping industry, this index is expected to play a key role for facilitating the construction and operation of environmentally-friendly ships.



Pure car and truck carrier with “STEP”

New technology to effectively utilize shipboard information

- Guidelines for installation of ship communication network for shipboard machinery

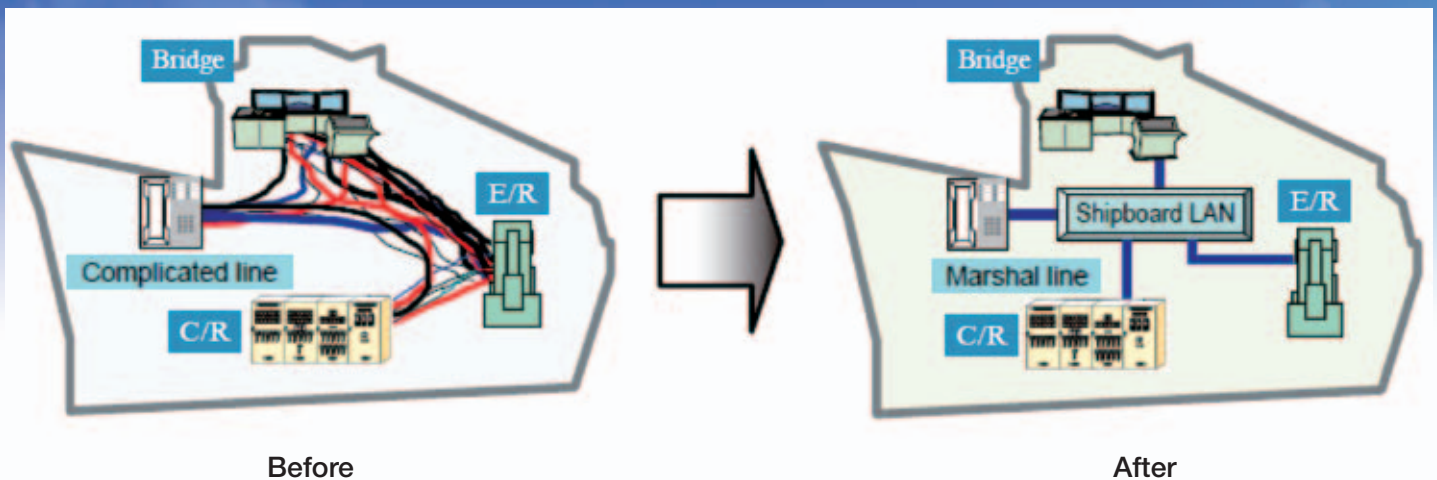

Various types of devices are installed on ships, helping them navigate safely. More often than not, each device has its own communication protocol, which makes it difficult to share information among those shipboard devices. This is also the reason why there are such a large number of cables interconnecting devices for information outputs/inputs from/to each device.

To improve the situation, Japan Marine Equipment Association / Shipboard LAN Project is working on various research projects aiming to integrate information/automatic control systems. The project team has conducted verification experiments for shipboard LAN system by connecting various devices manufactured by Japanese ma-

rine equipment manufacturers to a network, and it was successfully confirmed that shipboard LAN system allows information sharing among the devices, and that the installation of LAN system results in a significant reduction of cables. High reliability, redundancy and enhanced security of the network were also confirmed.

This system is expected to contribute to dissemination of large volume ship-shore communication (Fleet Broadband) technology in the future. Japan has already submitted a draft concerning this new technology to ISO (International Organization for Standardization) and IEC (International Electrotechnical Commission).

Environmentally Friendly, Fuel-saving Low-VOC Antifouling Paint "SEAFLO NEO"

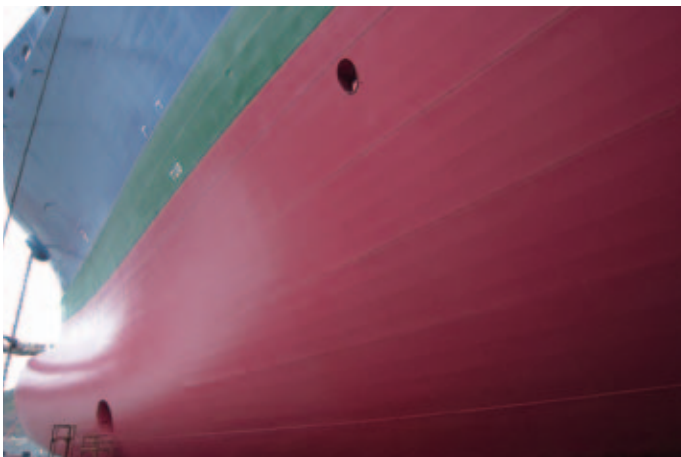

Chugoku Marine Paints, LTD. (CMP), established in 1917 in Hiroshima Japan, has since then developed and become a reputable manufacturer and distributor of Marine Coatings for seagoing ships globally. Today, the need is increasing for antifouling paints with fuel saving effect from reduced frictional resistance. To meet this demand, CMP introduced environmentally friendly fuel-saving low-VOC antifouling paint, SEAFLO NEO, integrating the latest technological achievements. SEAFLO NEO is a high performance TBT free hydrolysis antifouling, embodying for the first time a new technology using a new polymer unprecedented in its low viscosity to deliver an ultra smooth surface and excellent self-polishing performance, thus providing long term antifouling effect, low friction resistance and low-fuel consumption.

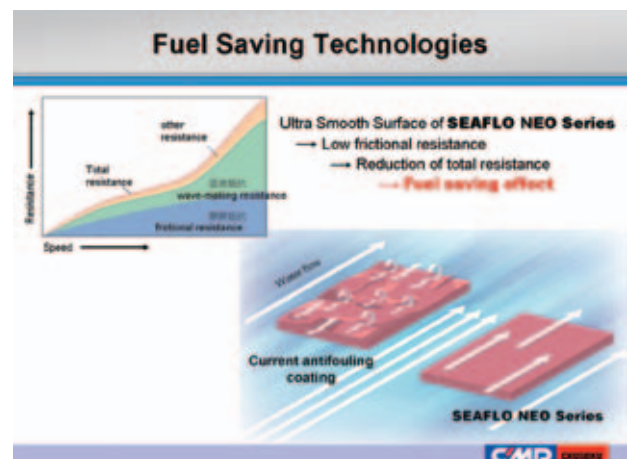

Friction is reduced by using a specific low viscosity resin and applying a surface-adjusting technique that gives a coat surface a low roughness and a long wavelength. The test proved that SEAFLO NEO reduces frictional resistance by 8% compared to conventional antifouling paints.

This provides 3 to 5% fuel saving when this new paint is applied to real ships.

Another characteristic of SEAFLO NEO is its low VOC content. It is the lowest (330g/L) in the hydrolysis category, and thanks to this characteristic, the quantity used per m² is reduced when this product is applied, ultimately reducing the absolute quantity of use, man-hours spent in application and the odor, among other respects.

Government-sponsored Official Development Assistance (ODA)

The government of Japan provides supports to developing countries for their economic and social developments through its Official Development Assistance (ODA) program. The program in maritime field centers around provision of ships such as ferries and work boats which help promote coastal shipping, and technical aids to facilitate development of maritime industry and to ensure maritime safety.

Today, the government is looking into the possibility to expand the program to providing supports for building “Marine transport terminal” and “offshore oil storage bases” using Japanese mega-float technology.

Japanese shipbuilding and marine equipment manufacturing industries intend to continue their efforts to contribute to the world through ODA programs in the maritime field.



Report of the 20th JECKU Top Executive Meeting



The 20th JECKU Top Executive Meeting was held on Oct. 27th, 2011 in Jeju Island, South Korea. This meeting provides a platform for executives of shipbuilding industry from Japan (J), Europe (E), China (C), Korea (K) and USA (U), which are shipbuilding great

powers, to join together, exchange views on the current situation of the industry and deepen mutual understandings. 82 leading shipbuilding executives attended this year's meeting from the 4 countries and 1 region referred above, including 26 from Japan. Mr. Kazuaki Kama, the chairman of The Shipbuilders' Association of Japan, was the head of Japanese delegates.

The followings are the summaries of noteworthy agreements in this year's meeting:

- It was acknowledged that it is important for the global shipbuilding industry as a whole, to have common opinions on international rules and regulations concerning shipbuilding industry discussed and developed at IMO (International Maritime Organization).
- Shipbuilding industry welcomes regulations on GHG emissions for environmental protection, and is determined to strive to develop eco-friendly ships with technical soundness.
- Given that the energy efficiency is significantly and sufficiently improved for the latest ships, shipbuilding industry intends to request related industries and governments for their supports in facilitating purchase of new ships.

Cooperation in Asia

The 5th Asian Shipbuilding Experts' Forum (or ASEF in short) was held on December 1st - 2nd 2011 in Busan, South Korea. This forum started in 2007 with its first conference in Tokyo, Japan, followed by the second in 2008 in Changwon, Korea, the third in 2009 in Shanghai, China, and the fourth in 2010 in Kyoto, Japan, all with great success.

About 120 experts participated in this year's forum from Asian countries including South Korea, China, Japan, Bangladesh, Indonesia, the Philippines, Sri Lanka, Thailand and Vietnam. Most participants are from shipbuilding industries, classification societies, research institutes and equipment manufactures.

At this forum, three topics were selected as its themes focusing on the global rules and standards, especially those developed by ISO and IMO, and presentations on those topics were delivered by the members. Such topics include: (1) Maritimes Safety(4 topics), (2) Equipment & Security (4 topics), (3) Presentations on the status of shipbuilding industry by Bangladesh and Sri Lanka.



In prior to the forum, meetings for 2 correspondence group - “Standardization of IHM” and “Consultative Status of IMO NGO” – were held on the day before, November 31st, and the results of the meetings were reported at the end of the forum by the coordinators.

Major Shipbuilding Related Organizations

Ministry of Land, Infrastructure, Transport and Tourism (MLIT)

Shipbuilding and Ship Machinery Division, Maritime Bureau, 1-3, Kasumigaseki 2-chome, Chiyoda-ku, Tokyo, 100-8918, Japan

Tel : +81-3-5253-8634 Fax : +81-3-5253-1644

Website : <http://www.mlit.go.jp>

Purpose :

The Maritime Bureau of the Ministry of Land, Infrastructure, Transport and Tourism takes necessary measures to develop shipping, shipbuilding and related Industries including promotion of the research and development on advanced ship technology, establishment of rules and regulations for ship safety and marine pollution, conducts of ship inspections and tonnage measurements as well as international cooperation through the OECD Council Working Party on Shipbuilding.

National Maritime Research Institute (NMRI)

Head Office

38-1, Shinkawa 6-chome, Mitaka, Tokyo, 181-0004, Japan

Tel : +81-422-41-3005 Fax : +81-422-41-3247

Website : <http://www.nmri.go.jp>

Purpose :

To implement the research and development of technologies for safe and efficient maritime transportation, effective utilization of marine resources and spaces, and marine environment protection.

The Nippon Foundation

The Nippon Zaidan Building 1-2-2 Akasaka, Minato-ku Tokyo 107-8404, Japan

Tel : +81-3-6229-5111 Fax : +81-3-6229-5110

Website : <http://www.nippon-foundation.or.jp/eng/index.html>

Purpose :

The Nippon Foundation is an organization that supports domestic and international activities. The scope of activities widely ranges from the ocean, ships, wellbeing, volunteers, international programs, arts, sports to education. In the field of the ocean and ships, the Nippon Foundation is engaged in such activities as the conduct of maritime research and development, offerings of international cooperation to secure ships safe navigation and the dissemination of maritime matters to young people.

Japan Ship Technology Research Association (JSTRA)

Round Cross AKASAKA, 10-9, Akasaka 2-chome, Minato-ku, Tokyo, 107-0052, Japan

Tel : +81-3-5575-6426 Fax : +81-3-5114-8941

E-mail: info@jstra.jp

Website : <http://www.jstra.jp>

Membership

Supporting members : 191

Purpose :

The key words of JSTRA - the objectives of JSTRA - are Regulations, Standards, and R&D.

JSTRA, providing a platform for tight cooperation among the industry, learned society and government in maritime cluster, contributes toward maritime safety, marine environment protection and development of maritime industries in the world through the effective of the above three objectives.

The Shipbuilders' Association of Japan (SAJ)

Toranomon 30 Mori Building,2-2, Toranomon 3-chome, Minato-ku, Tokyo, 105-0001, Japan

Tel : +81-3-5425-9521 Fax : +81-3-5425-9533

E-mail: info@sajn.or.jp

Website : <http://www.sajn.or.jp>

Membership

Full members : 19 shipbuilding companies

Member-association : The Cooperative Association of Japan Shipbuilders

Purpose :

To promote the sound development of shipbuilding industry, thereby to contribute to enhancing the national / world economy and public welfare.

The Cooperative Association of Japan Shipbuilders (CAJS)

Toranomon Mitsui Bldg. 10F, 8-1, Kasumigaseki 3-chome, Chiyoda-ku, Tokyo 100-0013, Japan

Tel : +81-3-3502-2061 Fax : +81-3-3503-1479

Membership

Ordinary members : 50 shipbuilding companies

Supporting members : 10 shipbuilding companies and 24 associations

Purpose :

To contribute to the progress and development of medium and small-size shipbuilders, promote their export marketing, and help related industries achieve further growth.

Overseas offices

- Singapore
- Dalian

Japan Ship Exporters' Association (JSEA)

Toranomon 30 Mori Building, 2-2, Toranomon 3-chome,
Minato-ku, Tokyo, 105-0001, Japan

Tel : +81-3-5425-9673 Fax : +81-3-5425-9674

E-mail : postmaster@jsea.or.jp

Website : <http://www.jsea.or.jp>

Membership

21 shipbuilding companies, 11 trading houses

Purpose :

To engage in activities for the prevention of unfair export transactions, establishment of orderly export marketing practices and promotion of the common interest of its members, and thereby to contribute to the sound development of ship export trade.

Overseas office

- London, Japan Ship Centre (JETRO)

Japan Marine Equipment Association (JSMEA)

Toranomon Toyo Kyodo Building, 13-3, Toranomon
1-chome, Minato-ku, Tokyo 105-0001, Japan

Tel : +81-(03)-3502-2041 Fax : +81-(03)-3591-2206

E-mail : info@jsmea.or.jp

Website : <http://www.jsmea.or.jp>

Membership

Ordinary members : 235 ship machinery manufacturing
companies and related companies in the Industry

Supporting members : 52 (including shipbuilding companies)

Purpose :

To expedite advancement and progress of marine
equipment, and any other marine industry related thereto.

Overseas offices :

- Shanghai
- London
- Singapore

Ocean Policy Research Foundation (OPRF)

Kaiyo Senpaku Building, 15-16, Toranomon 1-chome
Minato-ku, Tokyo, 105-0001, Japan

Tel : +81-3-3502 1828 Fax : +81-3-3502-2033

Website : <http://www.sof.or.jp>

Purpose :

Ocean Policy Research Foundation (OPRF) is conducting
a wide range of activities to help realize comprehensive
ocean management and sustainable development
of maritime industries. OPRF focuses its efforts in
three main areas: ocean-related researches, maritime
technology development, and international cooperation.
These activities have resulted into many proposals
beneficial to the maritime community.

Overseas Offices

• London :

Japan Ship Centre (JETRO)
Shipbuilding Department
Ship Machinery Department
MidCity Place, 71 High Holborn, London WC1V 6AL,
United Kingdom
Tel : +44-20 7421 8300
Fax : +44-20 7421 0009

• Shanghai :

Ship Machinery Department, JETRO Shanghai
21st Floor, Shanghai International Trade Centre
2201, Yan An Xi Road, Shanghai, 200336, P.R.C.
Tel : +86-21-6270-0489 ext.2600
Fax : +86-21-6270-0499

• Dalian :

Shipbuilding Department ,JETRO Dalian
SENMAO BUILDING 19F,
147 Zhongshan Road,Dalian 116011, CHINA
Tel : +86-411-8360-9418
Fax : +86-411-8360-9498

• Singapore :

Shipbuilding Department, JETRO Singapore
Ship Machinery Department , JETRO Singapore
Hong Leong Building, 16 Raffles Quay #38-05
Singapore 048581
Tel : +65-6429-9520
Fax : +65-6224-1169

• Seoul :

JETRO Seoul
3rd Floor, Young Poong Bldg., 33 Sorin-dong, Chongro-
ku, Seoul, REPUBLIC OF KOREA
Tel : +82-2-739-8657
Fax : +82-2-739-4658



Published by

Japan Ship Technology Research Association

The Shipbuilders' Association of Japan
 The Cooperative Association of Japan Shipbuilders
 Japan Ship Exporters' Association
 Japan Marine Equipment Association

Cooperation with

The Nippon Foundation

Maritime Bureau
 Ministry of Land, Infrastructure, Transport and Tourism of JAPAN

Copyright (c)2012 The Publishers
 All right reserved. No part of this book may be used or reproduced in any manner whatever without written permission except in the case of brief quotations embodied in critical articles and reviews.

Photo credit

Mitsubishi Heavy Industries Ltd.
 IHI Marine United Inc.
 Mitsui Engineering & Shipbuilding Co., Ltd.
 Niigata Power Systems Co., Ltd.
 Kawasaki Heavy Industries, Ltd.
 Kyokuyo Shipyards Corporation
 Naikai Zosen Corporation
 Chugoku Marine Paints, LTD.

Kawasaki Kisen Kaisha, Ltd.
 Mitsui O.S.K. Lines
 NYK LINE

Kamome Propeller Co., Ltd.
 National Maritime Research Institute (NMRI)
 SHIN KURUSHIMA TOYOHASHI SHIPBUILDING CO., LTD.
 TSUNEISHI SHIPBUILDING CO., LTD
 Universal Shipbuilding Corporation

Joe Nishizawa



The Nippon Foundation

